

CIBIE

Mini OSCAR® LED

(Ref.045300 full black – 045301 black & chrome)

Product & dimensions

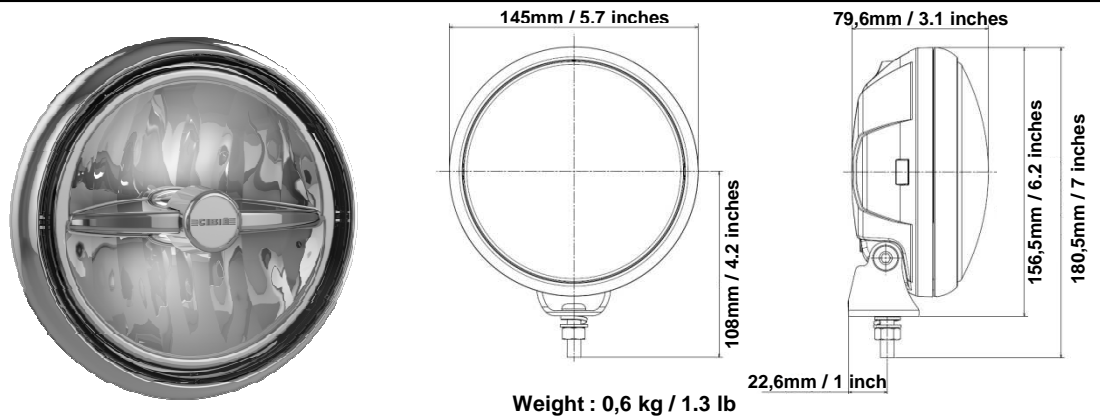

Beam pattern

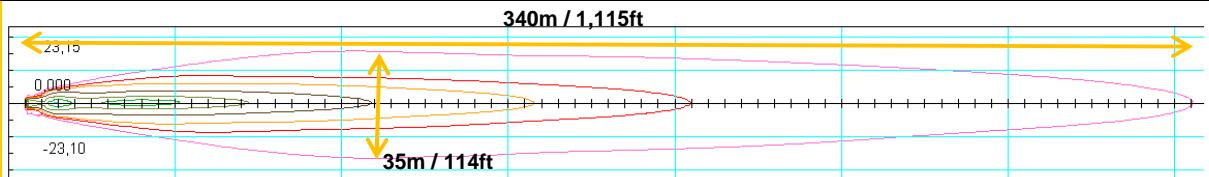

Technical characteristics

Product conception	Performances
Aluminum die casted housing Polycarbonate coated lens Polycarbonate aluminized reflector 2 high power LED Complex surfaces reflector Multi-positioning bracket 12/24 V	ECE reference index: 12,5 LED flux: 1,120 lumens Output flux: 560 lumens Luminous intensity: 75,000 candelas Light colour: 6,000 kelvins

Applications

Additional high beam for: small cars, 4WDs, pick-ups, trucks, heavy duties, agricultural vehicles, construction vehicles, marine boats, mining vehicles ...

USP

Characteristics	Advantages	Benefits
Performances	Optimized visibility & improved safety thanks to LED performing lighting Compliant with all international regulations Tested in extreme conditions EMC compatibility	Optical efficiency improved by +30% compared to halogen technology, highly homogeneous beam ECE / SAE / CCC homologated for road usage IP67, vibration 6G, working temperature: from -40°C to +70°C / -40°F to 158°F, corrosion and UV resistant ECE R10 + CISPR25 Class3
Design / Style	Compact and efficient	One of the lightest homologated high beams in the world: only 0,6kg / 1.3 lb
Innovation	Full LED technology Consumption 14W	White colour beam 5x less consuming than halogen

Spare parts

CIBIE® Cover x2
Ref: 047930

